

# MU 901/1801/UMTS-LX

Tripple-frequency Mobile Antenna  
for the 900 MHz, 1800 MHz and UMTS Bands

PROCOM



## DESCRIPTION:

- ★ Tripple-frequency antenna – three bands – one antenna!
- ★ Covering both EGSM/NMT-900, DCS-1800/PCN and UMTS.
- ★ For direct use with:
  - an EGSM/DCS-1800/PCN mobile phone (single or dual-band) or
  - an EGSM and a DCS-1800/PCN mobile phone or UMTS-terminal (requires diplexer, type DIPX 1000/1550).
- ★ Stainless steel LX-mount.
- ★ Especially suited for roof-mounting.
- ★ Provided with FME-connection (supplied without cable).
- ★ Bendable section in mount for adjustment of whip (tiltable 15° by hand).
- ★ Installation with access from the outside only (requiring an 18 mm dia. hole).

## SPECIFICATIONS:

ELECTRICAL	
MODEL	MU 901/1801/UMTS-LX
ANTENNA TYPE	Tripple-frequency mobile antenna
FREQUENCY	880-960 MHz (EGSM/NMT-900) 1710-1880 MHz (DCS-1800/PCN) and 1900-2200 MHz (UMTS)
IMPEDANCE	Nom. 50 Ω
POLARISATION	Vertical
GAIN	Approx. 0 dB on all bands (acc. to EIA RS-329-1)
BAND WIDTH	900 MHz: > 40 MHz @ SWR ≤ 1.5 1800 MHz: Approx. 200 MHz @ SWR ≤ 2.0 (typ.) 1900-2200 MHz @ SWR ≤ 2.0 (typ.)
SWR	≤ 2.0 on transmitter frequencies
MAX. POWER	25 watts
MECHANICAL	
MATERIALS	Whip: Black cover POM Black-chromed brass Mount: Stainless steel Brass Environment-proof plastics
RECOMMENDED INSTALLATION TORQUE	3.5 Nm max.
CABLE	FME-cable to be ordered separately
COLOUR	Black
HEIGHT	93 mm
WEIGHT	Approx. 33 g
MOUNTING	18 mm dia. hole

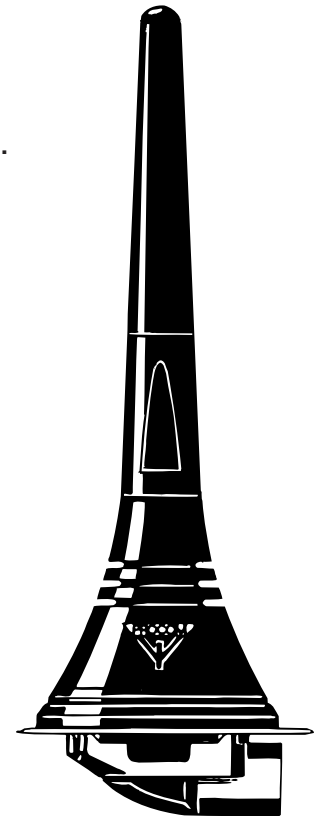

### OPERATION USING A DIPLEXER:

In case of operating two transceivers on one antenna at the same time, a diplexer, type DIPX 1000/1550, is necessary to complete the system. The tasks of the diplexer are to protect the two receiver inputs from being destroyed by the transmitter in the contrary band, and to ensure a low-loss path between the transceiver and the antenna, which is not loaded by the other branch. For further details please see the separate data sheet on the DIPX 1000/1550. The diplexer fully covers both bands and, consequently, tuning to specific frequencies is not required.

### COUPLING DIAGRAM:

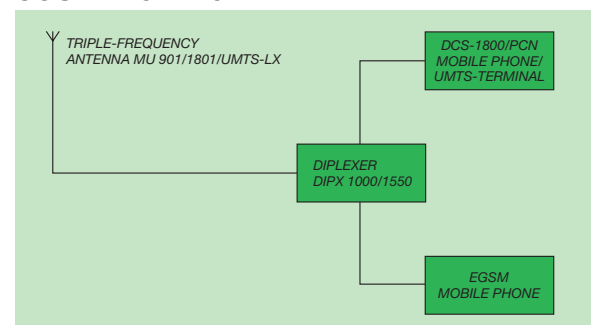

PROCOM A/S reserve the right to amend specifications without prior notice.

# MU 901/1801/UMTS-LX

## Installation



The LX-mount is especially suited for roof-mounting. It is recommended to mount the antenna at the centre of the roof to ensure the best omnidirectional coverage. Mounting can take place in an 18 mm dia. hole with access from the outside only. When cleaning the car in car-washing machines, the whip should be removed – a 9 mm fork spanner can be used. After wash, the whip is refitted and tightened lightly with the spanner. The mount is equipped with a bendable section ( $\pm 15^\circ$ ) to make it possible to adjust the antenna to an upright position.

### 1. INSTALLATION DIMENSIONS:

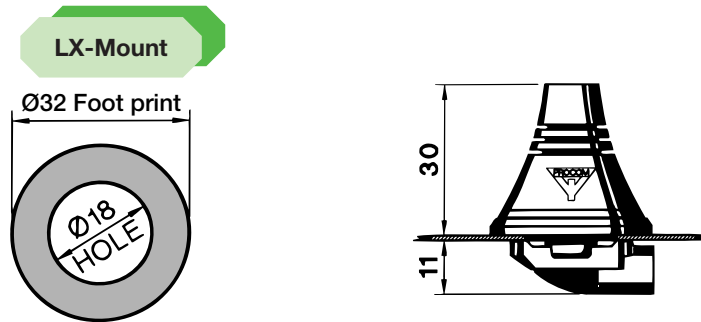

### 2. INSTALLATION STEPS:

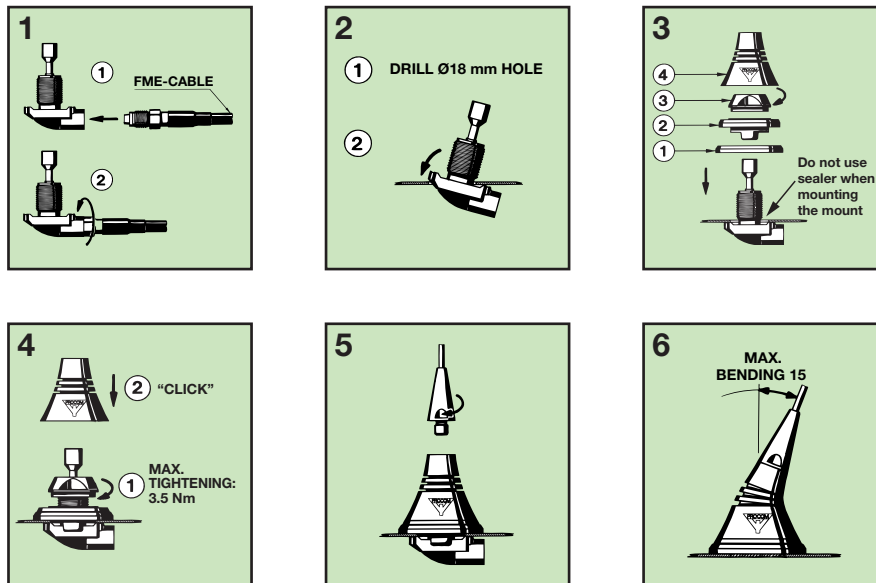

**PLEASE NOTE:** When tightening the revolving nut (see picture 4), special care must be taken to keep the spanner in the correct position.

### 3. TUNING:

The antenna is delivered factory-tuned and requires no further tuning.