

MU 911-ZG/...

Colinear 4 dB Mobile Antenna
for the 900 MHz Band

PROCOM

DESCRIPTION:

- ★ Encapsulated phasing coil.
- ★ Black-chromed stainless steel whip.
- ★ 3 models, type "l", "m" and "h" cover band segments suiting the most common 900 MHz CELLULAR networks such as EAMPS, ETACS, NMT-900 and EGSM.
- ★ Stainless steel ZG-mount with M8 x 1-thread whip-fastening system.
- ★ Simple mounting exclusively with access from the outside.
- ★ Choice between two connection principles:
 - ★ ZG-mount : FME-connection (supplied without cable).
 - ★ ZGP4-mount: Permanently attached 4 m low loss cable terminated with FME-connector.

ZG-Mount

ZGP4-Mount

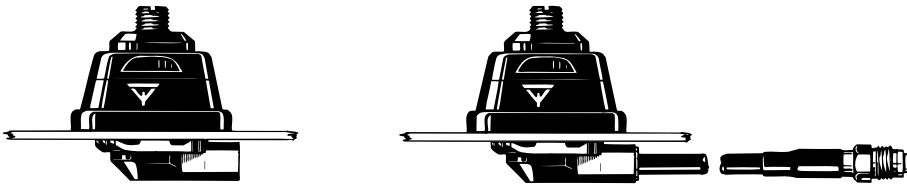

ORDERING DESIGNATIONS:

FRE-QUENCY RANGE	MOUNT VERSION	ZG-mount with FME	ZGP4-mount with 4 m cable and FME-connector
824-894 MHz (EAMPS)		MU 911-ZG/l	MU 911-ZGP4/l
872-950 MHz (ETACS)		MU 911-ZG/m	MU 911-ZGP4/m
880-960 MHz (EGSM & NMT-900)		MU 911-ZG/h	MU 911-ZGP4/h

To help selecting the correct model for a specific cellular network please consult the survey of cellular network frequencies under USEFUL DATA in our catalogues.

SPECIFICATIONS:

ELECTRICAL	
MODEL	MU 911-ZG/...
ANTENNA TYPE	Colinear mobile antenna
FREQUENCY	900 MHz-band – covered by three models
IMPEDANCE	Nom. 50 Ω
POLARISATION	Vertical
GAIN	4 dB (acc. to EIA RS-329-1)
BAND WIDTH	≥ 50 MHz @ SWR ≤ 1.5 ≥ 90 MHz @ SWR ≤ 2.0
SWR	≤ 1.3 @ f. res.
MAX. POWER	60 watts
MECHANICAL	
MATERIALS	Whip: Stainless steel and brass, black-chromed Mount: Black-chromed brass Environment-proof plastics Stainless steel
RECOMMENDED INSTALLATION TORQUE	7.5 ± 1 Nm
COLOUR	Black
HEIGHT	Approx. 35 cm
WEIGHT	ZG-version : Approx. 110 g ZGP4-version : Approx. 250 g
MOUNTING	21 mm dia. hole

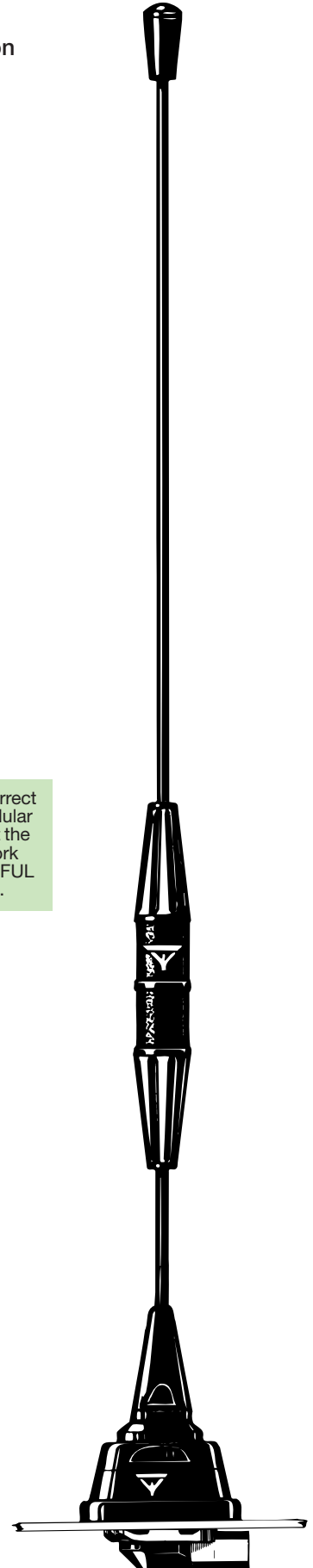

MU 911-ZG/...

Installation



This antenna should always be mounted on the car roof to ensure best omnidirectional coverage. The antenna is provided with our type ZG-mount for mounting from the outside in a 21 mm dia. hole.

The ZG-mount is provided with an M8 x 1 thread mount system. This construction meets the demand for a low-profile mobile mount with a slim appearance and with protection against theft of the antenna whip.

When cleaning the car in car-washing machines, the whip is easily removed using a spanner, size 12 mm. The whip is refitted again by screwing it onto the thread stud and tightening it with the spanner.

1. INSTALLATION DIMENSIONS:

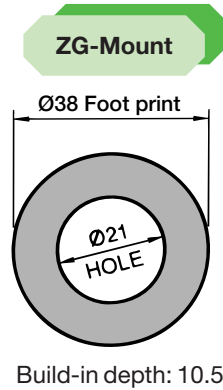

2. INSTALLATION STEPS:

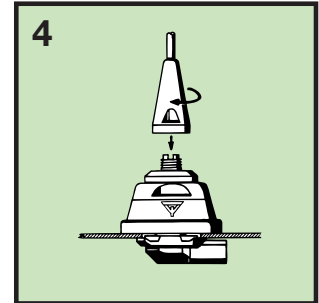
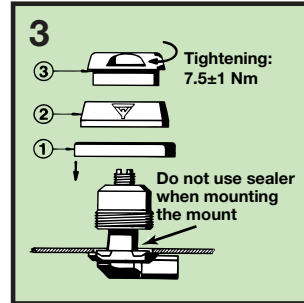
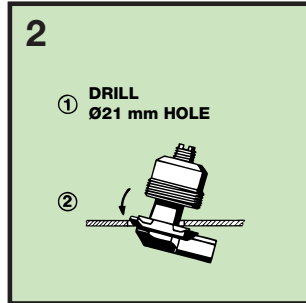
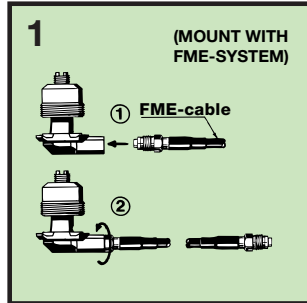

3. TUNING:

The antenna is delivered factory-tuned and requires no further tuning.