

MU 908-SM/...

Colinear 6 dB Mobile Antenna
for the 900 MHz Band

PROCOM

DESCRIPTION:

- ★ New whip design for optimum wind noise reduction.
- ★ Colinear mobile antenna with 6 dB gain (compared to $1/4 \lambda$ antenna).
- ★ Black conical glassfiber whip with shock spring.
- ★ Models available for the most common 900 MHz cellular networks (see below).
- ★ Excellent for combined radio broadcast reception and 900 MHz transceiving (requires a diplexer type LH 108/136 – to be ordered separately).
- ★ Elegantly designed SM-mount especially suited for mounting on the curved wings.
- ★ Supplied with three different packing gaskets for optimum adjustment to the wing contour.
- ★ M6-thread whip-fastening system.
- ★ Mount provided with FME-connection (supplied without cable).

ORDERING DESIGNATIONS:

FREQUENCY RANGE	TYPE NO.
824–894 MHz (EAMPS)	MU 908-SM/i
870–950 MHz (ETACS)	MU 908-SM/m
880–960 MHz (EGSM & NMT-900)	MU 908-SM/h

SPECIFICATIONS:

ELECTRICAL	
MODEL	MU 908-SM/...
ANTENNA TYPE	Colinear mobile whip antenna
FREQUENCY	Models within 824–960 MHz
IMPEDANCE	Nom. 50 Ω
POLARISATION	Vertical
GAIN	4–6 dB (compared to $1/4 \lambda$ antenna)
BAND WIDTH	≥ 20 MHz @ SWR ≤ 2.0
SWR	≤ 1.5 @ f.res.
MAX. POWER	60 watts
MECHANICAL	
MATERIALS	Whip: Black-lacquered conical glassfiber Black-chromed metal Mount: Brass Environment-proof plastics
RECOMMENDED INSTALLATION TORQUE	6.5 \pm 0.5 Nm
CABLE	FME-cable to be ordered separately
COLOUR	Black
HEIGHT	Approx. 710 mm (dep. on freq.)
WEIGHT	Approx. 166 g
MOUNTING	Wing mounting using one of the three packing gaskets supplied with the mount

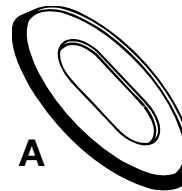

A

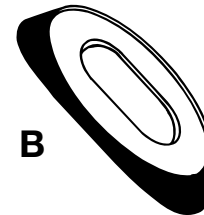

B

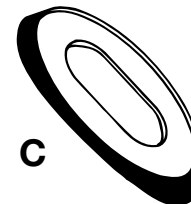

C



MU 908-SM/...

Installation



The SM-mount is especially designed for mounting on curved surfaces, e.g. the curved wings. The mount is supplied with three different packing gaskets to ensure the best possible adjustment to the wing contour at the desired location of the installation. Please refer to the installation steps described below. When cleaning the car in car-washing machines, the whip should be removed – a 9 mm fork spanner can be used. After wash, the whip is refitted and tightened lightly with the spanner.

INSTALLATION STEPS:

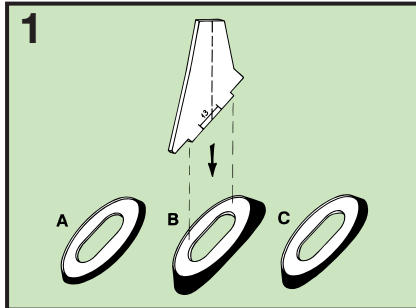

1. Installation tools.
To find a possible location for the installation of the SM-mount, the accompanying cardboard model of the mount may be used together with the three packing gaskets (types A, B and C). Which one of the packing gaskets to use depends on the angle and the curving of the wing.

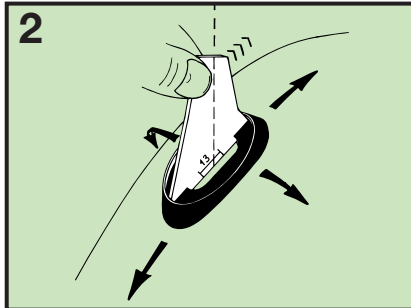

2. Determine a suitable location for the installation.
Use the cardboard model of the mount together with a packing gasket to check the fitting to the wing contour at the desired installation spot. Make sure that the desired positioning angle as indicated by the dotted line on the cardboard model can be obtained for the whip. If not, try another packing gasket or try moving the model to find an acceptable location for the installation. (The packing gasket should be oriented with the letter indicating the gasket type (A, B or C) at the bottom end). Check that there are no obstacles on the inside to prevent installation.

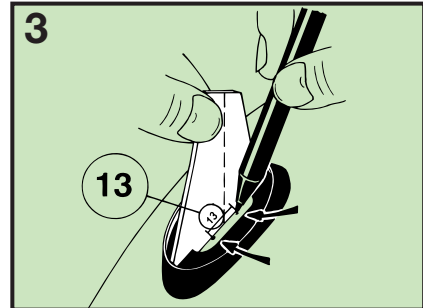

3. Mark the position for the SM-mount.
With the cardboard model in the correct position place two marks as indicated on the figure. The distance between the marks is 13 mm and the marks are to be placed as close to the cardboard model as possible. Remove the cardboard model and the packing gasket.

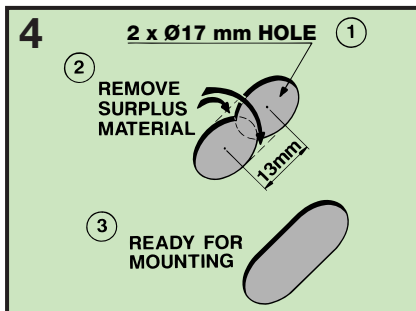

4. Make the hole for the installation.
The hole for the installation is made by drilling two 17 mm dia. holes with the marks as centres. The remaining metal between the holes is removed by cutting/nipping.

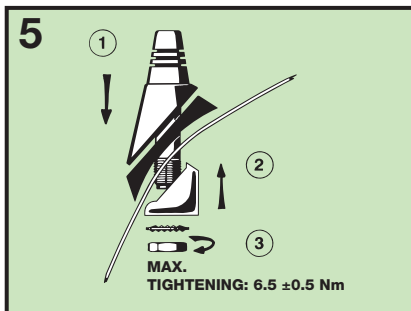

5. Install the SM-mount.
Install the SM-mount as shown in the figure. Fine-adjust the positioning of the whip before tightening the mount – recommended installation torque: 6.5 ± 0.5 Nm.

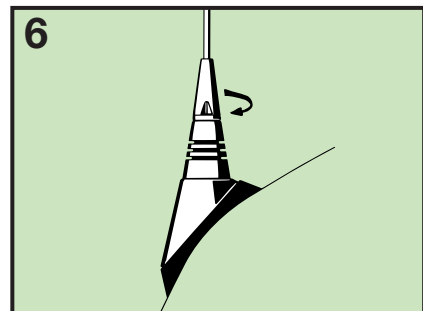

6. Fit the whip.
Fit the whip and tighten it lightly with a 9 mm fork spanner.

TUNING:

The antenna is delivered factory-tuned and requires no further tuning.