

# DFA 450/900-X/...

450 MHz/900 MHz  
Dual-frequency Mobile Antenna



## DESCRIPTION:

- ★ This antenna makes it possible to:
  - operate 450 MHz and 900 MHz transceivers alternately on the same antenna
  - operate two transceivers (450 and 900 MHz) at the same time on one antenna using a diplexer (type DIPX 500/800 – to be ordered separately)
  - operate a dual-frequency transceiver (450 and 900 MHz) on one antenna (diplexer not required).
- ★ Ready-tuned and unity gain on both bands.
- ★ Stainless steel X-mount with M6-thread whip-fastening system.
- ★ Simple mounting exclusively with access from the outside.
- ★ Models available with X-mount (oblong), CX-mount (circular) and MM-mount (magnetic).
- ★ Choice between two connection principles:
  - ★ X-mount, MM-mount : FME-connection (supplied without cable).
  - ★ XP4-mount : Permanently attached 4 m cable terminated with FME-connector.

X-Mount

CX-Mount

XP4-Mount

CXP4-Mount

MM-Mount

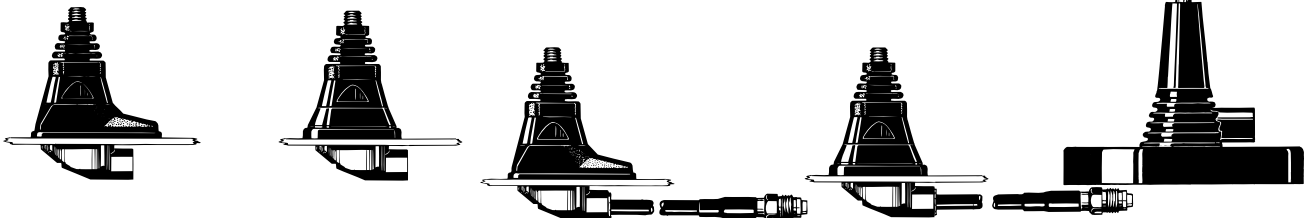

All whips are compatible with all mounts

## SPECIFICATIONS:

ELECTRICAL	
MODEL	DFA 450/900-X/...
ANTENNA TYPE	Dual-frequency mobile antenna
FREQUENCY	450 MHz-frequency to be stated within: 380–470 MHz 900 MHz-frequency to be stated within: 800–960 MHz
IMPEDANCE	Nom. 50 Ω
POLARISATION	Vertical
GAIN	Appr. 0 dB in both bands (acc. to EIA RS-329-1)
BANDWIDTH	450 MHz: > 25 MHz @ SWR ≤ 2.0 (typ.) 900 MHz: > 80 MHz @ SWR ≤ 1.5 (typ.)
SWR	≤ 1.5 on transmitter frequencies
MAX. POWER	50 watts
MECHANICAL	
MATERIALS	Whip: Black glassfiber Black-chromed brass Mount: Black-chromed brass Environment-proof plastics. Stainless steel
RECOMMENDED INSTALLATION TORQUE	4 ± 1 Nm
COLOUR	Black
HEIGHT	Approx. 140 mm
WEIGHT	X-version : Approx. 60 g XP4-version : Approx. 200 g MM-version : Approx. 270 g
MOUNTING	18 mm dia. hole



## ORDERING DESIGNATIONS:

When ordering, the operating frequencies in both bands must be stated. In case of duplex operation please specify TX and RX frequencies. In case of application for CELLULAR systems please state names of CELLULAR networks.

PROCOM A/S reserve the right to amend specifications without prior notice.

# DFA 450/900-X/... Installation



This antenna should be mounted on the car roof to ensure best omnidirectional coverage.

Mounting can take place exclusively with access from the outside when drilling an 18 mm dia. hole. Mounting can take place from the inside by drilling a 14 mm dia. hole. When mounting in a 14 mm dia. hole, remove the bottom plastic ring of the packing gasket with a sharp cutter.

When cleaning the car in car-washing machines, remove the whip using a spanner, size 9 mm. After wash, refit the whip and tighten it lightly with the spanner.

The MiniMag (abbreviated: MM) is a small, light-weight magnetic mount with a high attaching effect. A silicone layer applied to the contact surface protects the car roof and ensures maximum friction.

## 1. INSTALLATION DIMENSIONS:

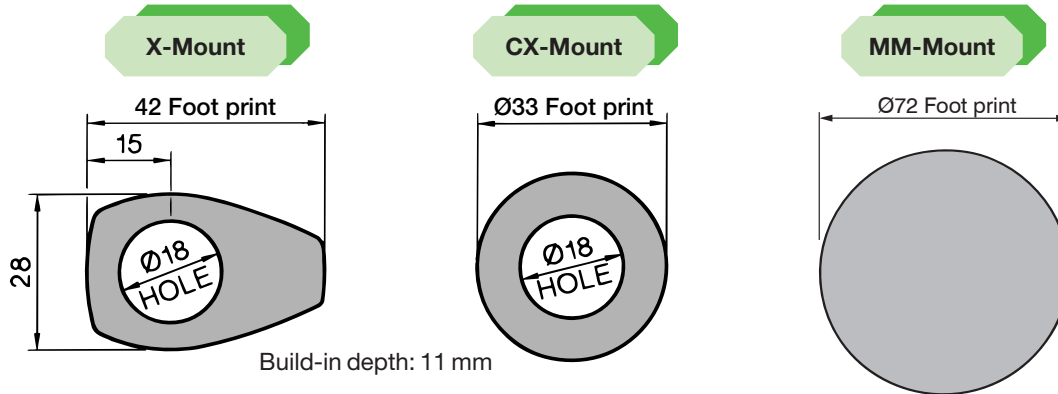

## 2. INSTALLATION STEPS:

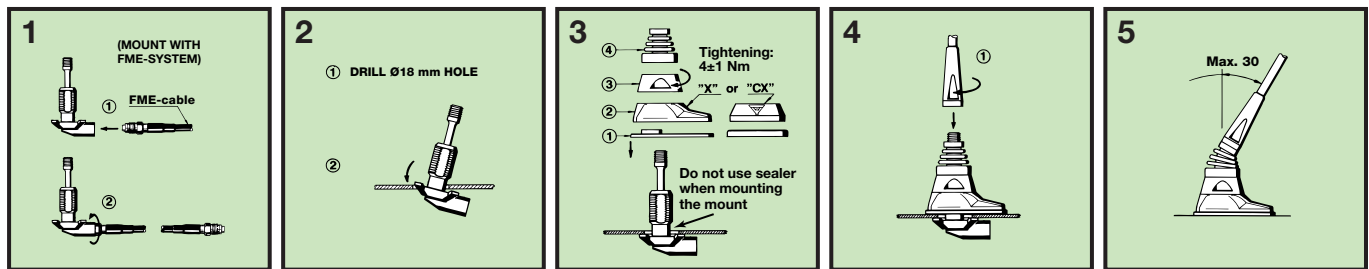

Several advantages are gained by using only one antenna. Only one single hole has to be drilled into the car body, only one cable installation has to be run, the car appearance is not destroyed by carrying several whips and also, it may be a particular demand that it should not be too obvious to see that the car is equipped with transceiving equipment.

In case of operating two transceivers on one antenna at the same time, a diplexer, type DIPX 500/800, is necessary to complete the system. (See the coupling diagram below). The tasks of the diplexer are to protect the two receiver inputs from being destroyed by the transmitter in the contrary band, and to ensure a low-loss path between the transceiver and the antenna, which is not loaded by the other branch. For further details please see the separate data sheet on the DIPX 500/800. The diplexer fully covers both bands and, consequently, tuning to specific frequencies is not required.

### COUPLING DIAGRAM:

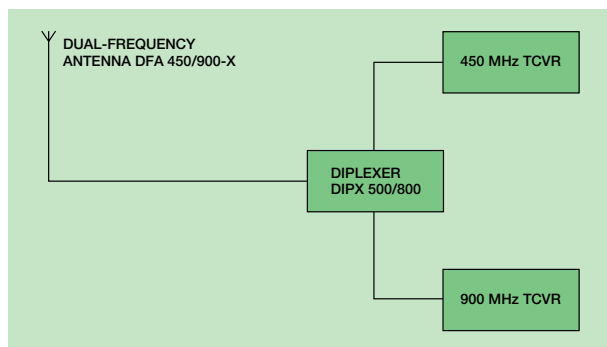

### PLEASE NOTE:

For safety reasons:

1. When using the DFA 450/900-MM, **car speed must not exceed 140 km/h.**
2. If operating the MM-mount with other whips, whip length must never exceed 320 mm, and utilizing this maximum length, car speed must not exceed 115 km/h.