

# DFA 450/900-ZG/...

450 MHz/900 MHz  
Dual-frequency Mobile Antenna



## DESCRIPTION:

- ★ This antenna makes it possible to:
  - operate 450 MHz and 900 MHz transceivers alternately on the same antenna
  - operate two transceivers (450 and 900 MHz) at the same time on one antenna using a diplexer (type DIPX 500/800 – to be ordered separately)
  - operate a dual-frequency transceiver (450 and 900 MHz) on one antenna (diplexer not required).
- ★ Ready-tuned and unity gain on both bands.
- ★ Stainless steel ZG-mount with M8-thread whip-fastening system.
- ★ Simple mounting exclusively with access from the outside.
- ★ Choice between two connection principles:
  - ★ ZG-mount : FME-connection (supplied without cable).
  - ★ ZGP4-mount : Permanently attached 4 m cable terminated with FME-connector.

ZG-Mount

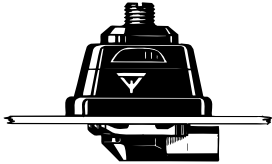

ZGP4-Mount

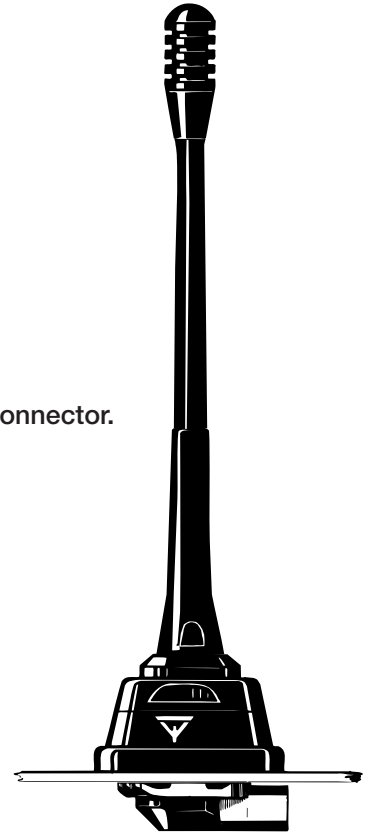
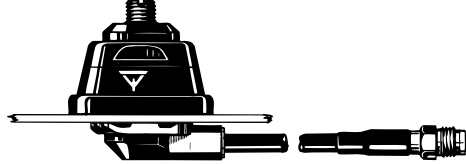

All whips are compatible with all mounts

## SPECIFICATIONS:

ELECTRICAL	
MODEL	DFA 450/900-ZG/...
ANTENNA TYPE	Dual-frequency mobile antenna
FREQUENCY	450 MHz-frequency to be stated within: 380–470 MHz 900 MHz-frequency to be stated within: 800–960 MHz
IMPEDANCE	Nom. 50 Ω
POLARISATION	Vertical
GAIN	Appr. 0 dB in both bands (acc. to EIA RS-329-1)
BANDWIDTH	450 MHz: > 25 MHz @ SWR ≤ 2.0 (typ.) 900 MHz: > 80 MHz @ SWR ≤ 1.5 (typ.)
SWR	≤ 1.5 on transmitter frequencies
MAX. POWER	50 watts
MECHANICAL	
MATERIALS	Whip: Black glassfiber Black-chromed brass Mount: Black-chromed brass Environment-proof plastics. Stainless steel
RECOMMENDED INSTALLATION TORQUE	7.5 ± 1 Nm
COLOUR	Black
HEIGHT	Approx. 160 mm
WEIGHT	ZG-version : Approx. 70 g ZGP4-version: Approx: 250 g
MOUNTING	21 mm dia. hole

### FME-SYSTEM ACCESSORIES

#### FME-CABLES

LENGTH	TYPE NO.
1m	1m FME
2m	2m FME
3m	3m FME
4m	4m FME
5m	5m FME
6m	6m FME
4m white	4m FME-white
6m white	6m FME-white
12m white	12m FME-white
18m white	18m FME-white

For further information about other types of FME-cables please compare the cable data sheets under accessories in our catalogue.

### FME-SYSTEM ACCESSORIES

#### FME-CONNECTORS

CONNECTOR	ORDER NO.
FME-FME	FME-FME
Prolongation	FMEP
N	FME-N
FSMA	FME-FSMA
BNC	FME-BNC
TNC	FME-TNC
UHF	FME-UHF
Mini-UHF	FME-MUHF
Elbow-MUHF	FME-EMUHF
Elbow-BNC	FME-EBNC
Elbow-TNC	FME-ETNC
SMA	FME-SMA

## ORDERING DESIGNATIONS:

When ordering, the operating frequencies in both bands must be stated. In case of duplex operation please specify TX and RX frequencies. In case of application for CELLULAR systems please state names of CELLULAR networks.

PROCOM A/S reserve the right to amend specifications without prior notice.

# DFA 450/900-ZG/...

## Installation



The ZG-mount is designed for mounting in a 21 mm dia. hole on horizontal surfaces as e.g. roof top or trunk lid, with access from the outside only.

A good contact surface on the inside of the car body must always be ensured, thus enabling the base plate to get in direct contact with the metal parts of the car, which is of utmost importance for proper performance of the antenna.

The ZG-mount is provided with an M8 x 1 thread mount system. This construction meets the demand for a low profile mobile mount with a slim appearance and with protection against theft of the antenna whip.

When cleaning the car in car-washing machines, the whip is easily removed using a fork spanner. The whip is refitted again by screwing it onto the thread stud and tightening it with the spanner.

### 1. INSTALLATION DIMENSIONS:

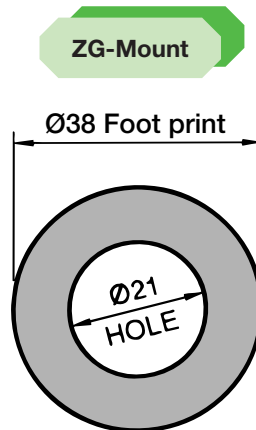

### 2. INSTALLATION STEPS:

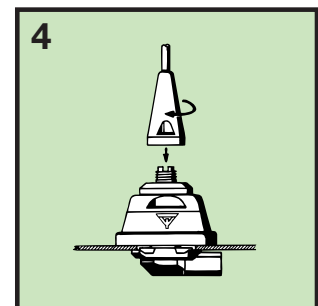
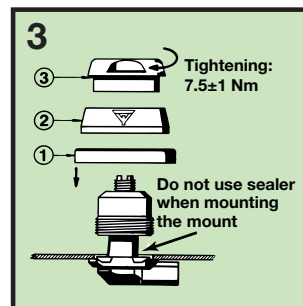
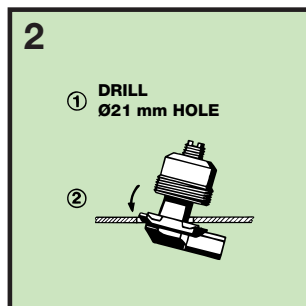
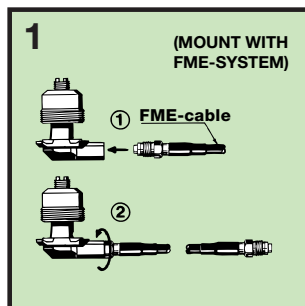

Do not use sealer on rubber gasket or other places.

Several advantages are gained by using only one antenna. Only one single hole has to be drilled into the car body, only one cable installation has to be run, the car appearance is not destroyed by carrying several whips and also, it may be a particular demand that it should not be too obvious to see that the car is equipped with transceiving equipment.

In case of operating two transceivers on one antenna at the same time, a diplexer, type DIPX 500/800, is necessary to complete the system. (See the coupling diagram below). The tasks of the diplexer are to protect the two receiver inputs from being destroyed by the transmitter in the contrary band, and to ensure a low-loss path between the transceiver and the antenna, which is not loaded by the other branch. For further details please see the separate data sheet on the DIPX 500/800. The diplexer fully covers both bands and, consequently, tuning to specific frequencies is not required.

### COUPLING DIAGRAM:

