

MU 5-ZG/...

Unity Gain $1/4 \lambda$ Mobile Antenna
for the 450 MHz Band

PROCOM

DESCRIPTION:

- ★ Sturdy, conical, flexible rubber whip.
- ★ MU 5-ZG/s covers 370–410 MHz
MU 5-ZG/l covers 406–440 MHz
MU 5-ZG/h covers 430–470 MHz
– no tuning required.
- ★ Stainless steel ZG-mount with M8-thread whip-fastening system.
- ★ Simple mounting exclusively with access from the outside.
- ★ Choice between two connection principles:
 - ★ ZG-mount : FME-connection (supplied without cable)
 - ★ ZGP4-mount : Permanently attached 4 m cable terminated with FME-connector.

ZG-Mount

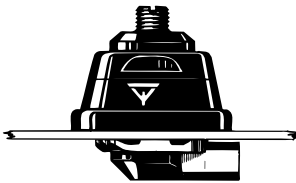

ZGP4-Mount

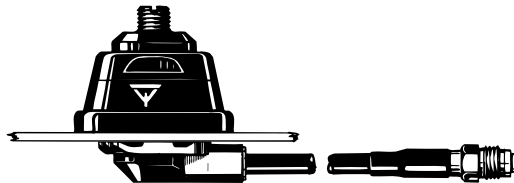

ORDERING DESIGNATIONS:

FRE-QUENCY RANGE	MOUNT VERSION	ZG-mount with FME	ZGP4-mount with 4 m cable and FME-connector
370–410 MHz		MU 5-ZG/s	MU 5-ZGP4/s
406–440 MHz		MU 5-ZG/l	MU 5-ZGP4/l
430–470 MHz		MU 5-ZG/h	MU 5-ZGP4/h

SPECIFICATIONS:

ELECTRICAL	
MODEL	MU 5-ZG/...
ANTENNA TYPE	$1/4 \lambda$ mobile whip antenna
FREQUENCY	450 MHz-band covered by three models
IMPEDANCE	Nom. 50 Ω
POLARISATION	Vertical
GAIN	0 dB (acc. to EIA RS-329-1)
BAND WIDTH	≥ 45 MHz @ SWR ≤ 1.5
SWR	≤ 1.2 @ f. res.
MAX. POWER	100 watts
MECHANICAL	
MATERIALS	Whip: Sturdy, flexible rubber with cast-in multicore steel wire radiating element Black-chromed brass Mount: Black-chromed brass Environment-proof plastics Stainless steel
RECOMMENDED INSTALLATION TORQUE	7.5 ± 1 Nm
COLOUR	Black
HEIGHT	Approx. 175 mm
WEIGHT	ZG-version : Approx. 130 g ZGP4-version : Approx. 270 g
MOUNTING	21 mm dia. hole



MU 5-ZG/... Installation



This antenna should always be mounted on the car roof to ensure best omnidirectional coverage. The antenna is provided with our type ZG-mount for mounting from the outside in a 21 mm dia. hole .

The ZG-mount is provided with an M8 x 1 thread mount system. This construction meets the demand for a low-profile mobile mount with a slim appearance and with protection against theft of the antenna whip.

When cleaning the car in car-washing machines, the whip is easily removed using a spanner, size 12 mm. The whip is refitted again by screwing it onto the thread stud and tightening it with the spanner.

1. INSTALLATION DIMENSIONS:

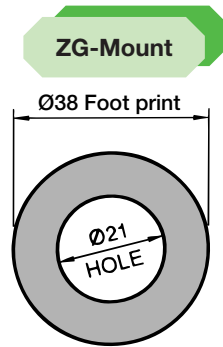

Build-in depth: 10.5 mm

2. INSTALLATION STEPS:

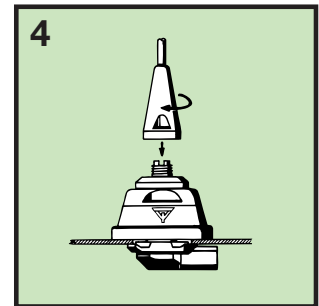
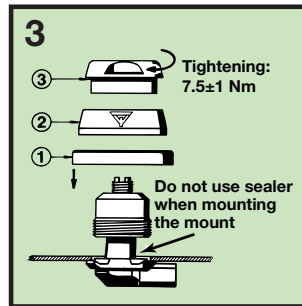
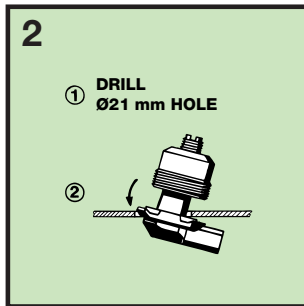
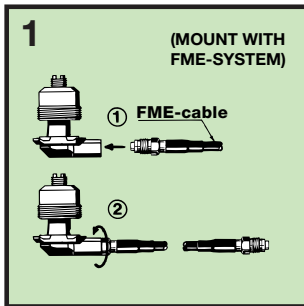

3. TUNING/MODEL CONVERSION:

The antenna is delivered factory-tuned and requires no further tuning.

To convert an MU 5-ZG/s model into an MU 5-ZG/l model, cut off 14 mm of the top end of the whip.

To convert an MU 5-ZG/l model into an MU 5-ZG/h model, cut off 8 mm of the top end of the whip.