

# CXL 70-5C/...

## Colinear, Heavy-Duty 5 dBd Marine and Base Station Antenna for the 450 MHz Band



### DESCRIPTION:

- ★ CXL 70-5C/... is a 5 dBd, vertically polarised, omnidirectional marine and base station antenna, which covers the 380–470 MHz band in 4 models with up to 10 MHz overlap.
- ★ The antenna is provided with our heavy-duty type “C” universal fixation bracket made of epoxy-coated, seawater resistant aluminium. The accompanying U-bolts and fittings are made of stainless steel.
- ★ CXL 70-5C/... can be mounted on 27 to 65 mm dia. mast tubes, and it is possible to lead the cable either along the inside or on the outside of the mast tube.
- ★ The carefully designed radiating element is sealed in a high-quality, conical glassfiber tube with low wind-load, which will ensure undisturbed performance by corrosive environments.
- ★ To substantially reduce noise caused by atmospherical discharges, all metal parts in the antenna are DC-grounded. Consequently, the antenna shows a DC-short across the coaxial cable.
- ★ The exceptional mechanical capabilities of this antenna ensure long dependable service in all environments.

### SPECIFICATIONS:

ELECTRICAL	
MODEL	CXL 70-5C/...
ANTENNA TYPE	Colinear, broad-banded
FREQUENCY	30 MHz wide frequency segments within 380–470 MHz. See model survey.
IMPEDANCE	Nom. 50 Ω
RADIATION	Omnidirectional
POLARISATION	Vertical
GAIN	7 dBi (5 dBd)
HALF POWER BEAMWIDTH	18°
BANDWIDTH	30 MHz
SWR	≤ 1.5
MAX. POWER	150 watt
ANTISTATIC PROTECTION	All metal parts DC-grounded (Connector shows a DC-short)
MECHANICAL	
TEMP. RANGE	-30° C → +70° C
CONNECTOR	N-female
WIND SURFACE	0.045 m <sup>2</sup>
WIND LOAD	50 N (at 150 km/h)
COLOUR	Marine white
MATERIALS	Shroud: Polyurethane coated glassfiber Mounting bracket: Seawater resistant aluminium, epoxy-coated Clamps: Stainless steel
TOTAL HEIGHT	Approx. 2.2 m (dep. on freq.)
DIA. IN TOP END	13 mm
DIA. IN BOTTOM END	25 mm
WEIGHT	Approx. 2.8 kg
MOUNTING	On 27–65 mm dia. mast tube

ORDERING DESIGNATIONS	
TYPE NO.	FREQUENCY
CXL 70-5C/s	380–410 MHz
CXL 70-5C/f	406–430 MHz
CXL 70-5C/l	420–450 MHz
CXL 70-5C/h	440–470 MHz

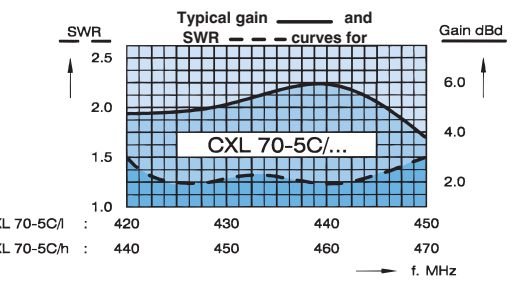
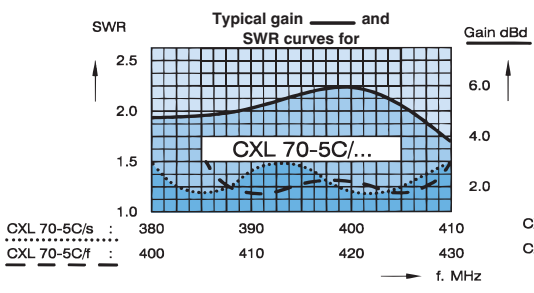
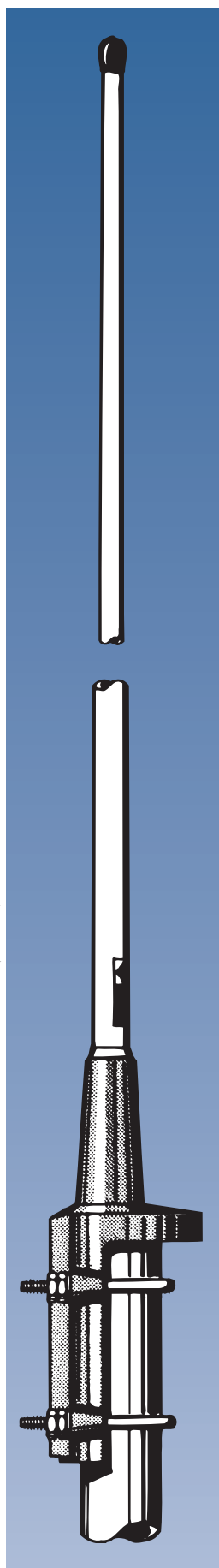
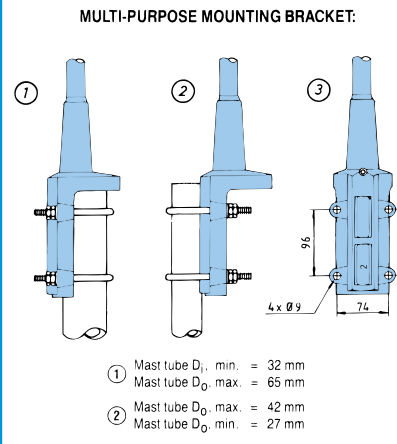

**CXL 70-5C/...**  
*Colinear, Heavy-Duty 5 dBd Marine and Base  
Station Antenna for the 450 MHz Band*



**TYPICAL RADIATION PATTERN (E-PLANE)**

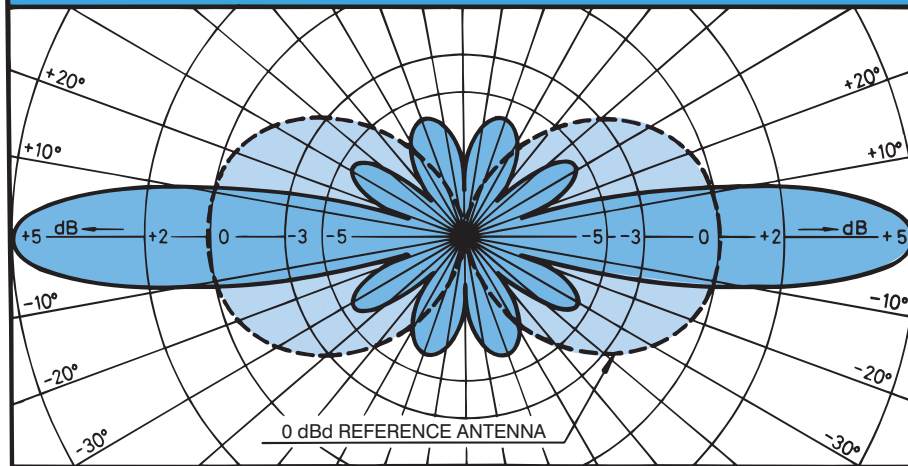

**TYPICAL RADIATION PATTERN (H-PLANE)**

