

# DIPX 500/800

Diplexer for the 0 - 500 MHz and 800 - 1300 MHz Ranges

## DESCRIPTION

- Diplexer for combining or splitting the two ranges 0 - 500 MHz and 800 - 1300 MHz.
- Excellent wide-band coverage – usable for a lot of applications.
- Extremely small dimensions.
- Quick installation using dual-adhesive pad provided.
- FME-connections on all terminals.

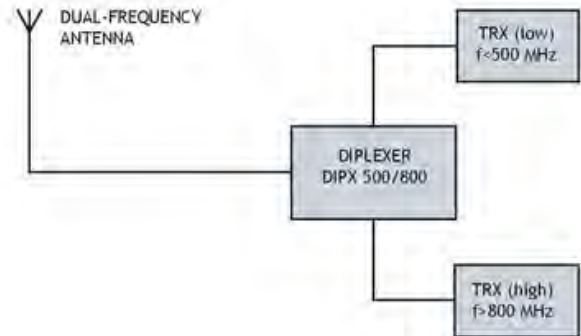
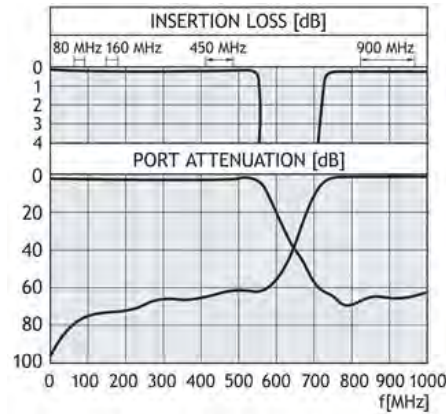

The DIPX 500/800 makes it possible to use only one antenna for the operation of two transceivers (one in each range). See the figure below. The antenna must be a dual-frequency antenna, that is, it must be resonant on the actual frequencies in the two bands. The transceivers may be used independently and will have no degrading influence on each other. Typically, the diplexer is installed next to the transceivers and only one cable is used between the diplexer and the antenna. The diplexer is suitable both for base station and mobile use.

The main tasks of the diplexer are to protect the individual receiver input from being destroyed by the transceiver in the contrary band and to ensure a low-loss path between the transceiver and the antenna which is not loaded by the other branch.

The diplexer can be operated together with any set of transceivers operating within the 0 - 500 MHz and 800 - 1300 MHz frequency bands.

Dual-frequency antennas are available for both mobile and base station applications.

## ORDERING DESIGNATIONS

TYPE	PRODUCT NO.
DIPX 500/800	200000742

## SPECIFICATIONS

ELECTRICAL	
MODEL	DIPX 500/800
FREQUENCY	Low port : 0 - 500 MHz High port : 800 - 1300 MHz
MAX. INPUT POWER	35 W each port
INSERTION LOSS	0 - 500 MHz : $\leq 0.5$ dB 800 - 1300 MHz: $\leq 0.7$ dB
ISOLATION	Low to high port: $\geq 45$ dB
IMPEDANCE	50 $\Omega$ on all terminals
MECHANICAL	
TEMP. RANGE	-30° C $\rightarrow$ +70° C
CONNECTORS	Low : FME High : FME Antenna: FME
DIMENSIONS (W x H x D)	50 x 21 x 50 mm
WEIGHT	Approx. 60 g



PROCOM A/S reserve the right to amend specifications without prior notice.

20/06/2011