

PRO-DIPX 88/136-N

Diplexer for the 0 - 88 MHz and 136 - 1300 MHz Ranges

DESCRIPTION

- Diplexer for combining or splitting the two ranges 0 - 88 MHz and 136 - 1300 MHz.
- Excellent wide-band coverage – usable for a lot of applications.
- N-connections on all terminals.



SPECIFICATIONS

ELECTRICAL	
MODEL	PRO-DIPX 88/136-N
FREQUENCY	Low port : 0 - 88 MHz High port : 136 - 1300 MHz
MAX. INPUT POWER	35 W each port
INSERTION LOSS	0 - 88 MHz : ≤ 0.7 dB 136 - 1300 MHz : ≤ 0.7 dB
ISOLATION	Low to high port: ≥ 45 dB
IMPEDANCE	50 Ω on all terminals
MECHANICAL	
TEMP. RANGE	-30° C \rightarrow $+70^{\circ}$ C
CONNECTORS	Low : N High : N Antenna: N
DIMENSIONS (W x H x D)	138 (incl. connectors) x 152 (incl. flanges) x 35 mm
WEIGHT	Approx. 325 g

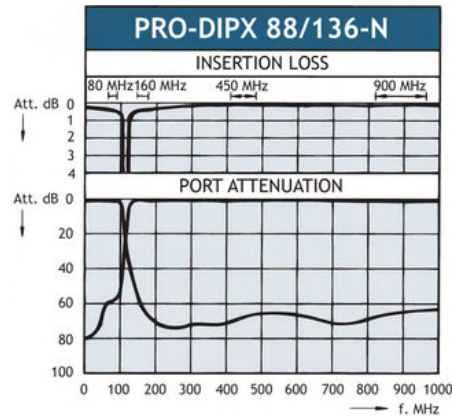

The PRO-DIPX 88/136-N makes it possible to use only one antenna for the operation of two transceivers (one in each range). See the figure below. The antenna must be a dual-frequency antenna, that is, it must be resonant on the actual frequencies in the two bands. The transceivers may be used independently and will have no degrading influence on each other. Typically, the diplexer is installed next to the transceivers and only one cable is used between the diplexer and the antenna. The diplexer is suitable both for base station and mobile use.

The main tasks of the diplexer are to protect the individual receiver input from being destroyed by the transceiver in the contrary band and to ensure a low-loss path between the transceiver and the antenna which is not loaded by the other branch.

The diplexer can be operated together with any set of transceivers operating within the 0 - 88 MHz and 136 - 1300 MHz frequency bands.

Dual-frequency antennas are available for both mobile and base station applications.

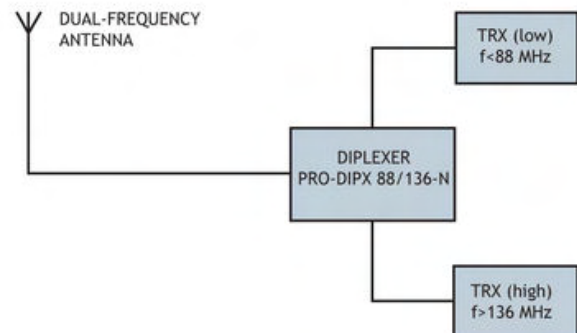

PROCOM A/S reserve the right to amend specifications without prior notice.

11/03/2009