

FILTERS

LPZ 1900

Coaxial Low-Pass Filter for the 1800 MHz Band



DESCRIPTION:

- ★ Passes all signals in or below the 1700-1900 MHz-band.
- ★ Rejects signals above this range.
- ★ Absolute stop band from 3.2 GHz to 12.4 GHz.
– no degradation at harmonics (Zolotarev-characteristic).
- ★ Attenuation in stop band better than 60 dB.
- ★ Insertion loss in pass range less than 0.4 dB.
- ★ Provided with brackets for panel mounting.

SPECIFICATIONS:

ELECTRICAL	
APPLICATION	Low-pass filter for the 1900 MHz band
FREQUENCY	Pass band: 1600-1900 MHz Stop band: 3.2-12.4 GHz
MAX. INPUT POWER	150 watt
INSERTION LOSS (PASS BAND)	≤ 0.4 dB
1 dB CUT-OFF FREQUENCY	> 1950 MHz
ATTENUATION (STOP BAND)	> 60 dB
MECHANICAL	
TEMP. RANGE	-30° C +80° C
CONNECTORS	N-female
DIMENSIONS (L x W x H)	95 x 40 x 36 mm
WEIGHT	Approx. 80 g

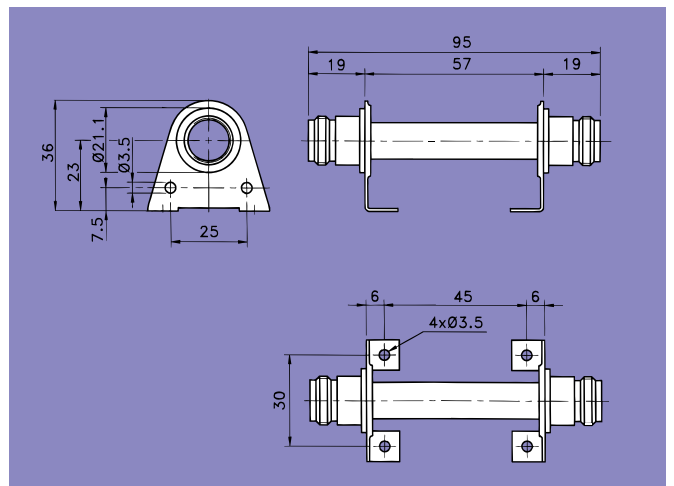
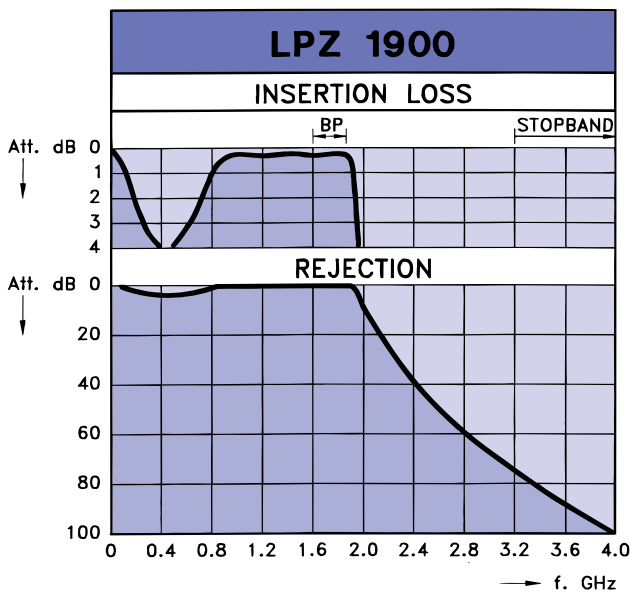

The LPZ 1900 is used to prevent RFI (Radio Frequency Interference) caused by excessive harmonic-generation from transmitters operating in the 1900 MHz band. By rejection, the filter reduces the amplitude of the harmonics and prevents them from being radiated by the antenna.
The filter is normally used in connection with base station transmitters, but as it is mechanically very ruggedly designed, it is perfectly suited for mobile and marine applications as well.

PROCOM A/S reserve the right to amend specifications without prior notice.