

PMC 1250

Phasing-Clamp for Creating a Certain Radiation Pattern using Two Antennas



DESCRIPTION:

- ★ The PMC 1250 can be used to create a certain desired radiation pattern in the horizontal plane using two vertically polarised antennas mounted side-by-side in a certain, prescribed distance, and feeding them both in the correct amplitude and phase relationship. The PMC 1250 is mainly designed for the 144-175 MHz band.
- ★ The PMC 1250 is equipped with two vertical 38 mm mast tube mounting studs for the two antennas. One of the tubes is welded permanently to one end of the supporting boom, and the other is able to slide along the boom where it can be fastened at an arbitrary distance. The position of the main clamp for the supporting mast can also be adjusted, and it should always be positioned halfway between the two antennas.
- ★ Mostly, the antennas are fed with currents of the same amplitude, and only the phase relationship and the distance between the antennas are varied to produce the desired coverage. The phase relationship is changed by introducing a delay line in one branch of the feeding cable system.
- ★ The figure below shows representative horizontal patterns for various values of distance D and phase delay P_d . Obviously, given a particular antenna site and a certain geographical area to be covered, a system like this offers a large degree of design-freedom to choose the best characteristic possible.
- ★ Please note that the PMC 1250 should always be mounted at the top of the supporting mast. If the PMC 1250 is sidemounted, the radiation pattern will be very difficult to predict.
- ★ PROCOM offers the service of designing and quoting systems like this especially according to the requirements of our customers.

SPECIFICATIONS:

FUNCTION	Phasing-clamp for creating a desired coverage
FREQUENCY	66- 88 MHz: $1/16 \lambda < D < 1/4 \lambda$ 144-175 MHz: $1/8 \lambda < D < 1/2 \lambda$
DISTANCE BETWEEN ANTENNAS (Variation range)	0.23-1.20 m
DIAMETER OF MOUNTING STUDS	$\varnothing 38$ mm
WIND SURFACE	0.10 m ²
WIND LOAD	127 N @ 160 km/h
MATERIALS	Boom: Hot dipped galvanized steel Fittings: Stainless steel
TOTAL HEIGHT	Approx. 1.28 m
WEIGHT	Approx. 8.0 kg
MOUNTING	On 38-65 mm outer diameter mast tube

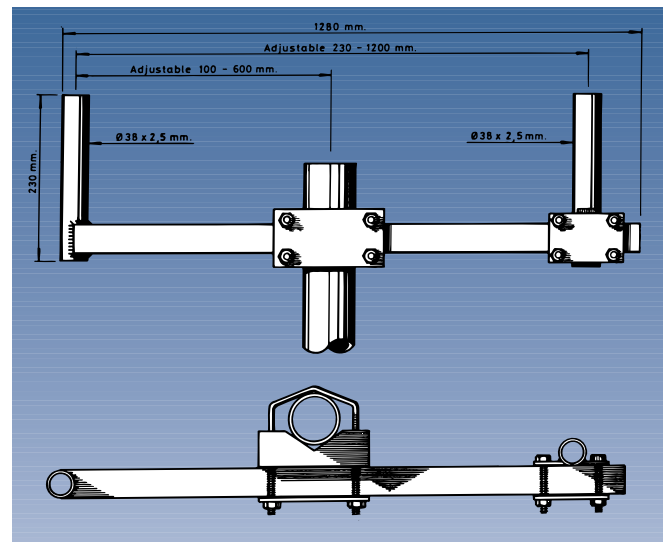

SURVEY OF RADIATION PATTERNS: (Relative field strength)

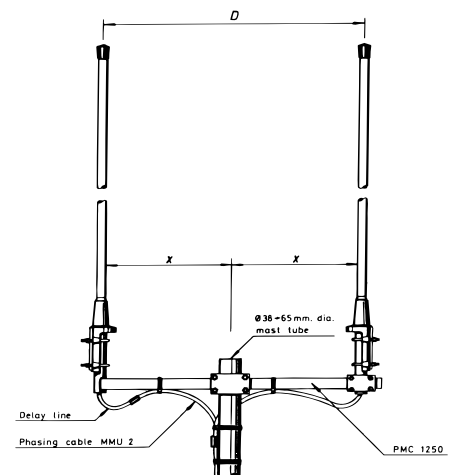
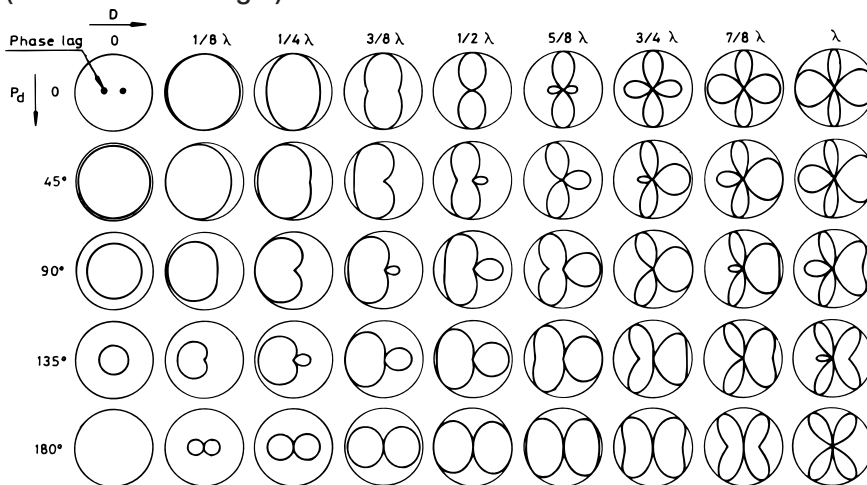

Antennas should be mounted symmetrically in relation to the mast

PROCOM A/S reserve the right to amend specifications without prior notice.