

BCL 1-KA

Active Receiving Antenna for 10 kHz–110 MHz



DESCRIPTION:

- ★ This receiving antenna consists of a high-capacitance antenna element combined with an amplifier which is built into the antenna mount.
- ★ The amplifier provides excellent impedance matching between the high-impedance antenna element and the 50 Ω downlead cable over an extremely wide bandwidth.
- ★ The amplifier is supplied with DC-power through the downlead 50 Ω coaxial cable by means of the supplied junction box which can be mounted in close vicinity to the receiving station. The junction box separates DC and RF-signals and can advantageously be fed from the same 12 V DC-power supply as the RX-station.
- ★ The sensitivity of the amplifier is optimized so that noise generated in the antenna and the receiver is always less than noise picked up by the antenna. The amplifier is protected against RF-overload and violent discharges and the large dynamic range ensures excellent cross and intermodulation properties.
- ★ The earthing wire (see drawing) ensures a low loss connection to ground for RF-signals, and thereby also prevents noise pick-up from the ship's installations running on the outside of the coaxial cable. As the earthing wire is AC-coupled, electrolytic corrosion is effectively prevented.
- ★ The junction box is protected against accidental polarity reversal and it is filtered to avoid interference pick-up.
- ★ The junction box is provided with FME-connectors for the antenna and the receiver ports. 1 m FME-cable and an FME-UHF connector is included for connecting the box to the receiver as well as an FME crimp connector for the downlead cable (RG 58).
- ★ The antenna is designed to withstand the roughest of weather and climate conditions and it is perfectly suited also for marine purposes.
- ★ The BCL 1-KA is delivered with the "SM-MA" mast mounting bracket.
- ★ The antenna is now delivered with a new and modified version of the amplifier making it possible also to receive FM-radio (88–108 MHz).

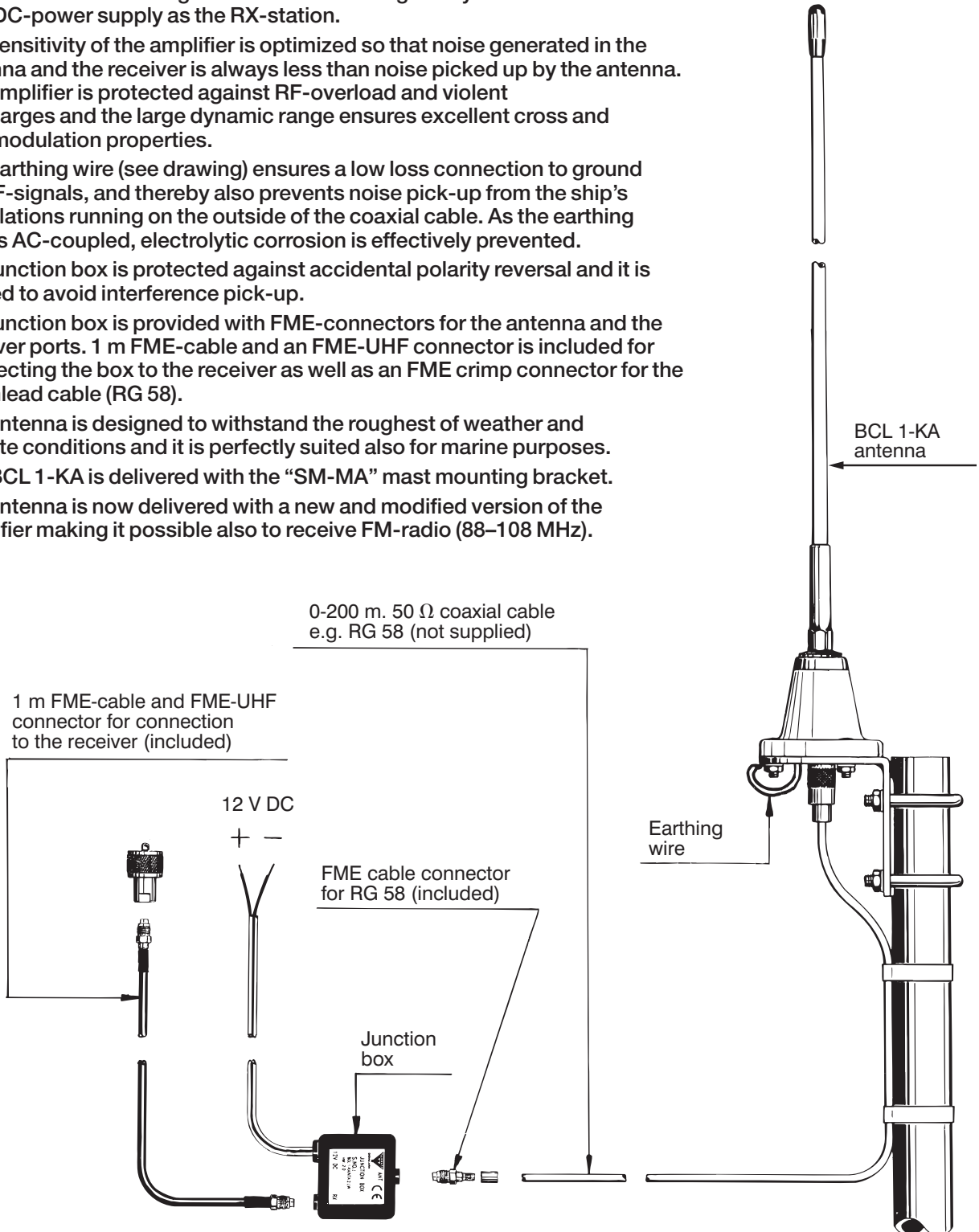

BCL 1-KA

Active Receiving Antenna for 10 kHz–110 MHz



ANTENNA SPECIFICATIONS:

ELECTRICAL	
MODEL	BCL 1-KA
ANTENNA TYPE	Broadband active receiving antenna
FREQUENCY	10 kHz–110 MHz
IMPEDANCE	Nom. 50 Ω
POLARISATION	Vertical
HORIZ. COVERAGE	Omni-directional
SUPPLY VOLTAGE	12 V DC (9–14 V)
CURRENT CONSUMP.	Approx. 60 mA
MAX. INTENSITY OF RECEIVED FIELD	Distortion due to amplifier voltage limitation occurs at field intensities exceeding 5 V/m
AERIAL PROTECTION	Spark gap
MECHANICAL	
TEMP. RANGE	-30° C → +60° C
CONNECTOR, ANT.	UHF (for PL 259)
CONNECTORS, JUNCTION BOX	Antenna: FME-connector (M) RX: FME-connector (M)
CABLE/CONNECTOR	1 m FME-cable and FME-UHF included. FME-cable connector for RG 58 downlead cable included
WIND SURFACE	0.0259 m ²
WIND LOAD	28.8 N @ 150 km/h
COLOUR	Marine white
MATERIALS	Shroud : Glassfiber and chromed brass MA housing: Lexan and chromed brass
TOTAL HEIGHT	Approx. 0.92 m (1.01 m incl. mounting bracket)
DIA. IN TOP END	7 mm
DIA. IN BOTTOM END	10 mm
WEIGHT	Approx. 600 g (800 g incl. mounting bracket)
MOUNTING	On 30–44 mm dia. mast tube or on a flat surface

FME-SYSTEM ACCESSORIES

FME-CABLES

LENGTH	TYPE NO.
1m	1m FME
2m	2m FME
3m	3m FME
4m	4m FME
5m	5m FME
6m	6m FME
4m white	4m FME-white
6m white	6m FME-white
12m white	12m FME-white
18m white	18m FME-white

For further information about other types of FME-cables please compare the cable data sheets under accessories in our catalogue.

FME-SYSTEM ACCESSORIES

FME-CONNECTORS

CONNECTOR	ORDER NO.
FME-FME	FME-FME
Prolongation	FMEP
N	FME-N
FSMA	FME-FSMA
BNC	FME-BNC
TNC	FME-TNC
UHF	FME-UHF
Mini-UHF	FME-MUHF
Elbow-MUHF	FME-EMUHF
Elbow-BNC	FME-EBNC
Elbow-TNC	FME-ETNC
SMA	FME-SMA

INSTALLATION DETAILS USING SM-MA MOUNTING BRACKET:

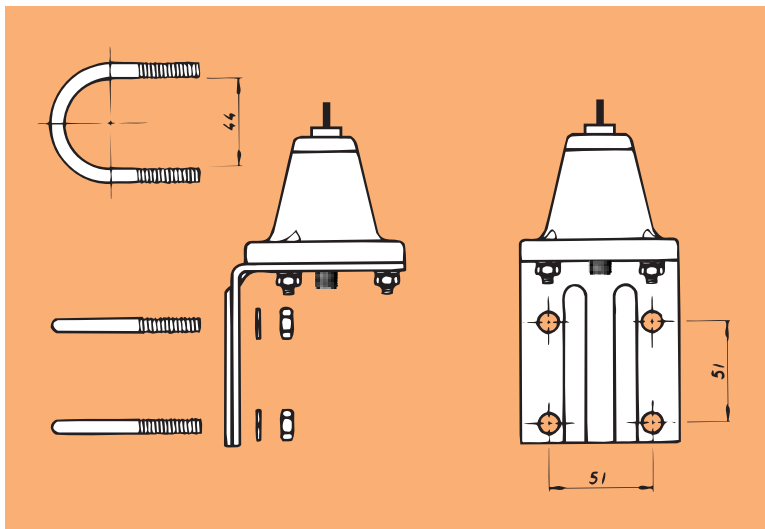

INSTALLATION DETAILS FOR MOUNTING ON FLAT SURFACES:

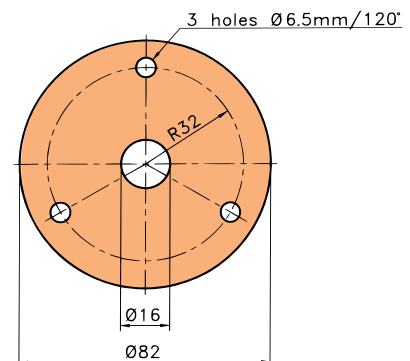

APPLICATION INFORMATION:

Several advantages can be gained by using an active antenna instead of an ordinary wire antenna. Firstly, the small physical size makes the active antenna much easier to install. Secondly, a wire antenna requires a matching unit which has a narrow bandwidth, making retuning necessary for every new listening frequency. In an active antenna, tuning is carried out “automatically”. Considering that the active antenna yields signal to noise ratios and signal strengths normally only obtainable with much longer wire antennas, an active antenna makes a good choice, especially also with respect to economy.

PROCOM A/S reserve the right to amend specifications without prior notice.